

**Architectural Products Built  
Today for a Better Tomorrow**

- **Storefront Window System  
SS3500**
- **SlimFront Window  
SS3520**
- **Storefront Entry Door  
SE3550**



**Commercial**  
Architectural Products



**CommercialCGI.com**



Both SS3500 and SS3520 Storefront Window Systems designed specifically to be used in tandem with the SE3550 Entry Door

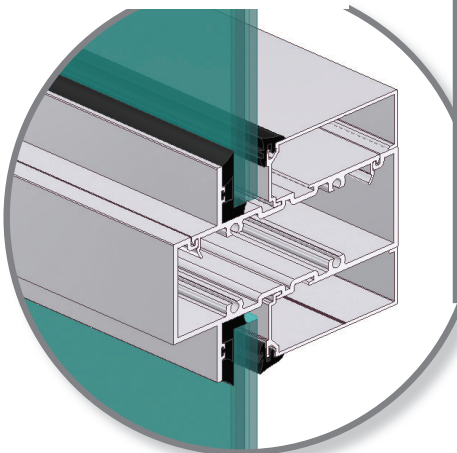

**STOREFRONT WINDOW SYSTEM SS3500**

- **GLASS**
  - 9/16" Laminated
  - 1 1/4" Laminated insulating
  - High performance low-E & tints
- **DESIGN PRESSURES**, up to +90/-120, provide security, safety and performance in wind-borne debris areas
- **NARROW SIGHT LINES**, 1.75" x 5", increases visibility without compromising structural integrity
- **ROBUST SIZES** – up to 12' high
- **EXTERNAL WET GLAZED**, system creates an exterior barrier, reducing the worry of water infiltration. Unlike internally drained systems, water does not have an opening to enter
- **GLAZING** is fully captured on all four sides
- White, bronze or clear anodized finishes available –Optional custom colors

**SLIMFRONT WINDOW SYSTEM SS3520**

- **GLASS**
  - 9/16" Laminated
  - 1 1/4" Laminated insulating
  - High performance low-E & tints
- **DESIGN PRESSURES**, up to +90/-120, provide security, safety and performance in wind-borne debris areas
- **NARROW SIGHT LINES**, 1" x 5" system with Slim Sightlines
- **ROBUST SIZES** – up to 12' high
- **EXTERNAL WET GLAZED**,
- **INSIDE GLAZED**
- **GLAZING** is fully captured on all four sides, 2 part silicone DOW 983
- White, bronze or clear anodized finishes available –Optional custom colors
- No jamb anchor required

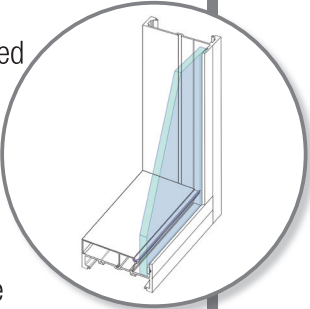

**STOREFRONT ENTRY  
 DOOR SE3550**
**➤ GLASS**

- 3/16" Laminated
- 1 1/4" Laminated insulating
- High performance low-E & tints

**➤ SINGLE AND DOUBLE DOORS**

- Max Door Sizes 48" x 120" or 96" x 120"
- Outswing configurations
- With optional transoms

**➤ DESIGN PRESSURES,**

up to +90/-120, provide security, safety and performance in wind-borne debris areas

**➤ STANDARD THREE-POINT LOCKING SYSTEM**

with two-point on inactive side

**➤ White, bronze or clear anodized finishes available**

–Optional custom colors

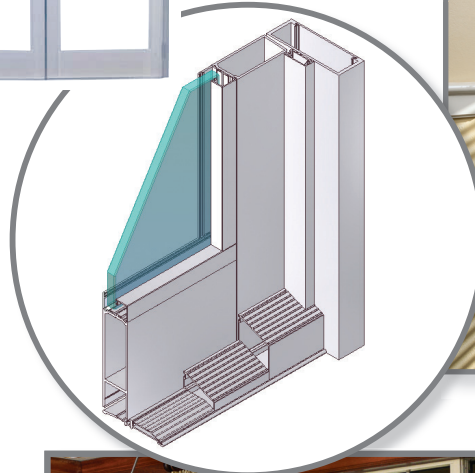
**➤ Designed to be used in tandem with the SS3500 and SS3520**
**➤ 10" Bottom Rail for ADA compliance**
**➤ Many available upgrade options including panics, closers, and threshold choices**



Bringing together industry-leading solutions, CGI Commercial is committed to being a trusted partner with architects, engineers, glaziers and dealers in the commercial market. We offer pre-glazed storefront window and door systems configured for some of the most demanding commercial and residential applications in the industry. CGI Commercial provides customers with personal services, product reliability, integrity, quality and on-time delivery.



COM01-0318

[CommercialCGI.com](http://CommercialCGI.com)

2970 NW 75th Avenue | Miami, FL 33122 | 305.718.8890 | E-mail: [info@CommercialCGI.com](mailto:info@CommercialCGI.com)